

INSTRUCTIONS

for INSTALLATION OPERATION and MAINTENANCE

POWERSTAT® VARIABLE TRANSFORMERS

WITH POWERKOTE® COILS - 146-246 Series

The right to make engineering refinements on all products is reserved. Dimensions and other details are subject to change.



Telephone and Fax Numbers
Telephone 860-507-2025
Fax 860-507-2050
Customer Service 860-507-2025, Ext. 70782
Product Application 860-507-2025, Ext. 72058

Toll-Free (in USA and Canada only)
Telephone 1-800-787-3532
Fax 1-800-821-1369
Customer Service 1-800-787-3532, Ext. 70782
Product Application 1-800-787-3532, Ext. 72058



Printed in USA

INSPECTION

A POWERSTAT Variable Transformer is a precision product packed with care. When unpacking, examine carefully for any shipping damage. Inspect the brush contact with particular care. The "Damage and Shortage" Instructions packed with the unit outline the proper procedure to follow if any parts are damaged or missing.

INSTALLATION

NOTE- The unit should be protected from any dust or debris that may be encountered while drilling holes, installing wiring, etc., during installation.

MANUALLY OPERATED ASSEMBLIES

All models are designed so that the same unit can be either bench or back-of-panel mounted as desired. The units as shipped are arranged for bench mounting. To change to back-of-panel mounting, proceed as outlined.

SINGLE UNITS

POWERSTAT Variable Transformer types 146 and 246 have four slots in the base for mounting. The mounting bolts can be located anywhere within the slots.

BENCH OR WALL MOUNTING

1. Locate and drill the desired set of mounting holes (four holes "A" or "B" or within the slot) using Drilling Template No. 1.
2. Place the unit in position. Insert and tighten four 3/8" mounting bolts.

BACK-OF-PANEL MOUNTING

1. Using the four slots between "A" or "B" holes on Drilling Template No. 1, locate and drill four mounting bolt holes. Also locate and drill the three dial screw holes "C" and the center shaft hole "D". The dial screw holes must be tapped to accommodate the 6-32 screws supplied. Maximum panel thickness is 3".
2. Loosen the knob setscrews and remove the knob. Remove the dial and mount it to the panel with the three 6-32 screws.
3. Loosen the shaft setscrews (at the base end of the shaft) and slide the shaft through so it will project about 1-1/16" through the panel after installation.
4. Place the unit in position. Insert and tighten four 3/8" mounting bolts. Place the knob on the shaft and position the pointer correctly with respect to the brush position and the dial indications. Tighten the knob setscrews.

GANGED ASSEMBLIES

BENCH OR WALL MOUNTING

1. On Standoffs
 1. Locate and drill the mounting bolt holes (four holes "A") using Drilling Template No. 1.
 2. Place the unit in position. Insert and tighten 3/8-24 mounting bolts. The mounting bolt length should not exceed the panel thickness plus 1/2".
2. On Side Brackets
 1. Locate and drill the four mounting bolt holes using Drilling Template No. 2. BE SURE TO USE THE PROPER SET OF HOLES.
 2. Insert and screw in part way the two top mounting bolts.
 3. Place the unit in position and insert the two bottom bolts. Tighten all mounting bolts.

BACK-OF-PANEL MOUNTING

1. Locate and drill the four mounting bolt holes "A", the three dial screw holes "C" and the center shaft hole "D" using Drilling Template No. 1. Maximum panel thickness is 3". The three dial screw holes must be tapped to accommodate the 6-32 screws supplied.
2. Remove the knob and the dial. Loosen the shaft setscrews (at the base end of each unit) and slide the shaft through so it will project about 1-1/16" through the panel after installation. Turn the radiators of the units to the extreme counterclockwise position and tighten the shaft setscrews. Recheck to be sure that the brushes are properly aligned.
3. Mount the dial to the panel with the 6-32 screws supplied.
4. Place the unit in position. Insert and tighten four 3/8-24 mounting bolts. Mounting bolts are supplied with the unit for use with panels to 3/4" thick. For thicker panels use 3/8-24 bolts 1/2" longer than the panel thickness. A ganged assembly, because of its added length and weight, requires extra support in the form of a shelf or cradle. Turn the brushes of the units to the extreme counterclockwise position and tighten the setscrews.
5. Place the knob on the shaft and position the pointer correctly with respect to the brush position and the dial indications. Tighten the setscrews.

MOTOR-DRIVEN ASSEMBLIES

Motor-driven POWERSTAT Variable Transformers of the 146-246 Series, both single units and ganged assemblies, may be bench or wall mounted in the same manner as manually operated ganged assemblies. Three-ganged assemblies, however, have three side brackets requiring 6 mounting bolts as shown in Drilling Template No. 2.

PARALLELING CHOKES

If an application's current requirement is greater than a single variable transformer's per phase rating, it is common practice to use a larger model. In some cases this is not possible either because there is no larger model or the physical requirements of the application do not allow it. For these applications, parallel-connected units can be used. These parallel connections require paralleling choke(s) in addition to the POWERSTAT® Variable Transformer, which may be mounted in any convenient position. Paralleling choke T5587 is available for this connection and must be ordered separately.

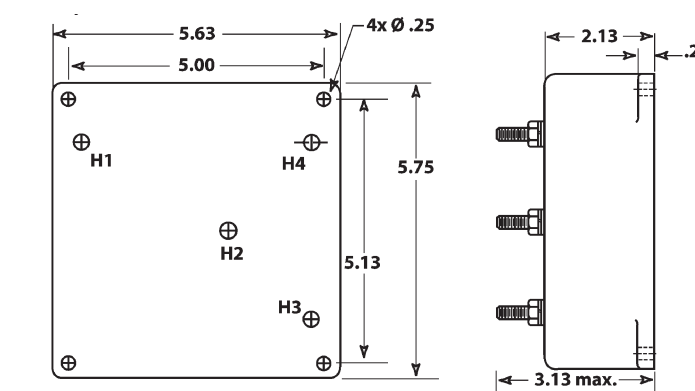

FIG. A
T5587 CHOKE
OUTLINE

NOTE: H1, H2, H3, and H4
are 1/4" Studs x 1" long.

MAINTENANCE

With ordinary care, a POWERSTAT Variable Transformer should require no servicing except possible replacement of the brush assembly. The brush should be inspected periodically and replaced if arcing takes place or if it is badly worn. Because the brush must be of a special material, replace only with a Superior Electric brush assembly listed below. The assembly is designed to assure perfect contact of the brush to the commutator regardless of brush position and length of time in use. Take care to avoid scraping, scratching or marring the commutator surface. Follow these steps to install a new brush assembly:

1. Remove the plate block above the terminal panel.
2. Unfasten the brush assembly anchor screws, remove and discard the old brush assembly.
3. Insert the new brush assembly in the radiator slot, replace the anchor screws and tighten to the radiator. Be sure that the back end of the brush strap is under the projections at the rear of the radiator brush slot.
4. Raise the brush and place a piece of sandpaper (grit #400 or finer) between the commutator surface and the brush so that the smooth side is on the commutator and the abrasive side is against the carbon brush.
5. While holding the sandpaper in place (flat), rotate the radiator through a short arc. Remove the sandpaper and blow out the excess carbon particles.
6. Rotate the radiator several times to check for smooth travel of the brush over the commutator surface. The brush should fit flat over the entire commutator surface. No space should be visible between the brush and the surface.

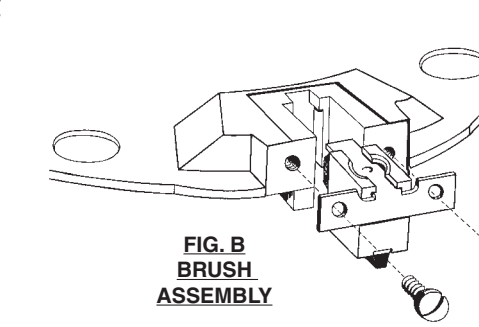

FIG. B
BRUSH
ASSEMBLY

REPLACEMENT BRUSH ASSEMBLIES

MODEL NUMBER	PART NUMBER	DESCRIPTION
146	176012-001	RB146
246	176012-002	RB246

Whenever unusual mechanical or electrical difficulties are encountered in the operation or installation of your POWERSTAT Variable Transformer, consult Superior Electric.

CONNECTIONS AND RATINGS

Important connection notes. Please read carefully.

- CONNECTIONS AND RATINGS given in these instructions are those most commonly used. In addition, all ganged units may be connected so that the units operate electrically independent on a common shaft. When this is desired, connections and ratings for a single deck unit should be used.
- For ambient temperatures between -20°C and +50°C use current ratings given in the charts. Figure C shows the output current de-rating required above 50°C.
- Coil to terminal connections for all 146 and 246 Series units are shown in Figures D and E.
- The connection diagrams are labeled "L" for Line Connections, "B" for Boost Connections and "S" for Step-Up Connections.
- For the Step-Up Connections, the Ratings Chart shows maximum output current rating for output voltages up to 125% of the input voltage, and maximum KVA at maximum output voltage. The output current must be reduced according to the curve in Figure G for output voltages greater than 125% of input voltage. Maximum KVA may be calculated using the rating curve in Figure G for voltages less than maximum.

- Clockwise (CW) and counterclockwise (CCW) rotation connections shown in the Ratings Chart and Connection Diagrams are for motor driven units and manual units with the knob on the radiator end. For connections with the knob on the base end, use the shown CCW connection for CW operation, and shown CW connection for CCW operation.
- Fuses are recommended on all units as shown (\$) and are supplied on F models. Supplied fuses are 30 ampere on 146 types, and 15 ampere on 246 types.
- COMMON shown in the connection diagrams is used as third leg in 3-phase open delta, or neutral in single-phase 3-wire and 3-phase 4-wire wye configurations. COMMON is not used in single-phase 2-wire or 3-phase 3-wire wye configurations. Jumper(s) provided in standard common position should be moved or removed as required.
- Motor drive wiring is shown in Figure F.
- For connections #9 and #10, a paralleling choke is required in addition to the POWERSTAT® Variable Transformer.
- For connections #11 and #12, two paralleling chokes are required. Paralleling choke T5587 is available for this connection and must be ordered separately. Wire per the appropriate diagram.

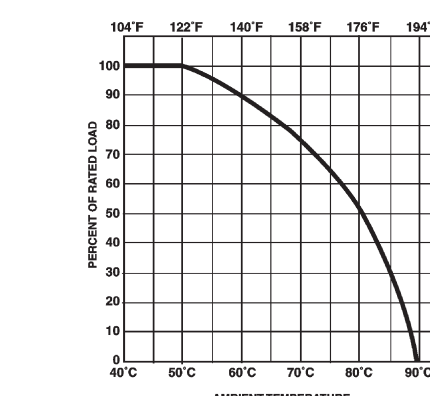

OPERATION AT TEMPERATURES ABOVE 50°C
FIGURE C

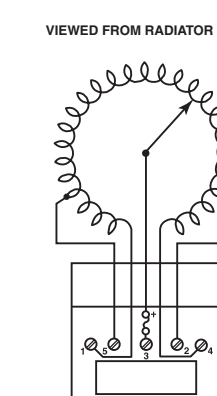

146 TYPES
FIGURE D

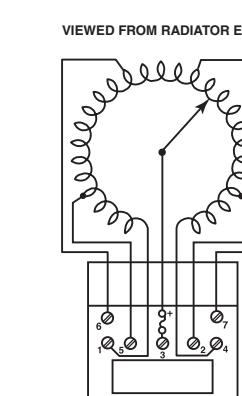

246 TYPES
FIGURE E

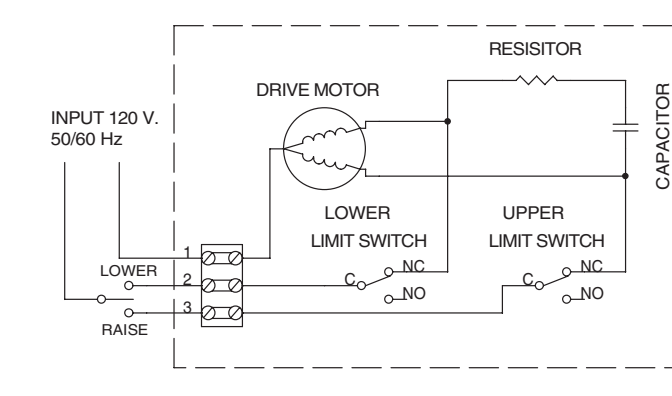

MOTOR DRIVE WIRING
FIGURE F

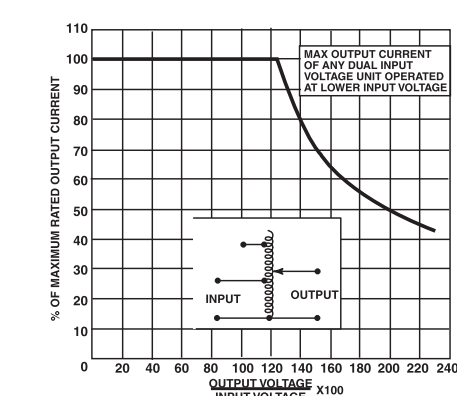

OPERATION IN "STEP-UP" CONNECTION
FIGURE G

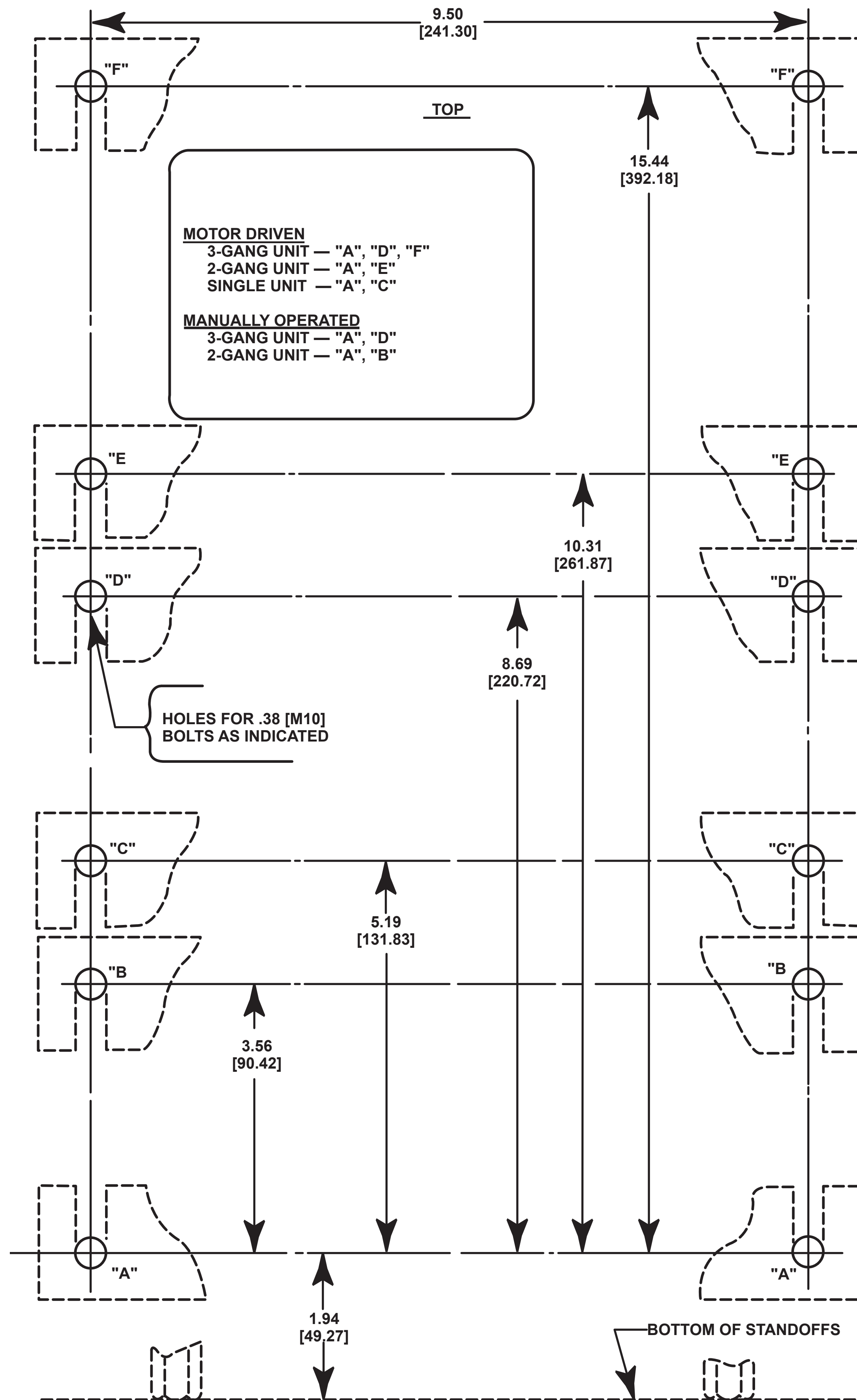

TEMPLATE NO. 2

CONNECTION DIAGRAMS

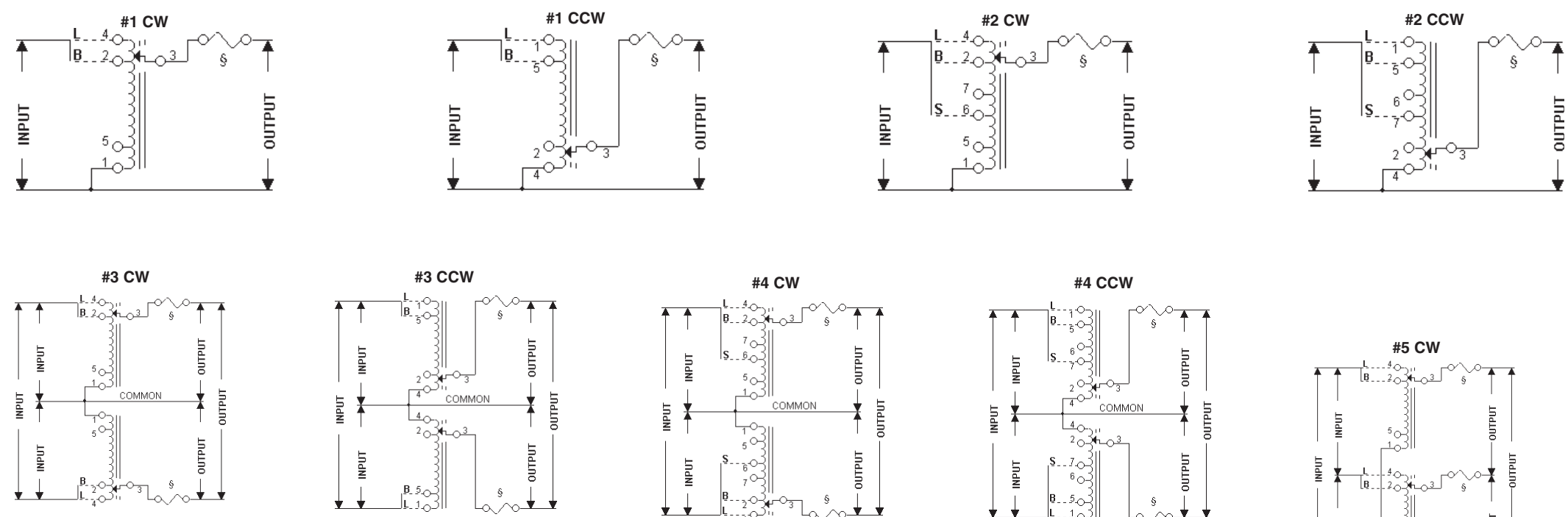

RATINGS CHART

120 VOLT, SINGLE PHASE																
"LINE" CONNECTION				"BOOST" CONNECTION				"STEP-UP" CONNECTION				Model Numbers				
Output Voltage: 120				120				N/A								
Output Voltage: 0-120				0-120				0-240								
Constant Current Load				Constant Impedance Load				Terminals & Rotation				Manually Operated				
Freq. (Hz)	Max. Amps	Max. KVA	Max. Amps	Max. KVA	Input CW	Output CW	Jumper CW	Freq. (Hz)	Max. Amps	Max. KVA	Input CW	Output CW	Jumper CW	Manually Operated	Motor Driven	Conn. Diag.
50/60	30	3.6	35	4.2	1-4	1-3	3-4	50/60	30	4.2	1-2	1-3	3-4			1
50/60	60	7.2	70	8.4	1-4	1-H2	1-1, 4-4	50/60	60	8.4	1-2	1-H2	1-1, 2-2			9
50/60	90	10.8	105	12.6	1-4	1-H2	1-1, 1-4, 4-4, 4-4	50/60	90	12.6	1-2	1-H2	1-1, 1-2, 2-2, 4-4, 5-5, 5-5			11

240 VOLT, SINGLE PHASE																
"LINE" CONNECTION				"BOOST" CONNECTION				"STEP-UP" CONNECTION				Model Numbers				
Output Voltage: 240				240				120								
Output Voltage: 0-240				0-240				0-280								
Constant Current Load				Constant Impedance Load				Terminals & Rotation				Manually Operated				
Freq. (Hz)	Max. Amps	Max. KVA	Max. Amps	Max. KVA	Input CW	Output CW	Jumper CW	Freq. (Hz)	Max. Amps	Max. KVA	Input CW	Output CW	Jumper CW	Manually Operated	Motor Driven	Conn. Diag.
50/60	15	3.6	19	4.6	1-4	1-3	3-4	50/60	15	4.2	1-2	1-3	3-4			2
50/60	30	7.2	35	8.4	4-4	3-3	1-1	50/60	30	8.4	2-2	3-3	1-1			3
50/60	30	7.2	38	9.1	1-4	1-H2	1-1, 4-4	50/60	30	8.4	1-2	1-H2	1-1, 2-2			10
50/60	45	10.8	57	13.7	1-4	1-H2	1-1, 1-4, 4-4, 4-4	50/60	45	12.6	1-2	1-H2	1-1, 1-2, 2-2, 4-4, 5-5, 5-5			12

480 VOLT, SINGLE PHASE																
"LINE" CONNECTION				"BOOST" CONNECTION				"STEP-UP" CONNECTION				Model Numbers				
Output Voltage: 480				380				240								
Output Voltage: 0-480				0-380				0-280								
Constant Current Load				Constant Impedance Load				Terminals & Rotation				Manually Operated				
Freq. (Hz)	Max. Amps	Max. KVA	Max. Amps	Max. KVA	Input CW	Output CW	Jumper CW	Freq. (Hz)	Max. Amps	Max. KVA	Input CW	Output CW	Jumper CW	Manually Operated	Motor Driven	Conn. Diag.
50/60	15	7.2	19	9.1	4-4	3-3	1-1	50/60	15	8.4	2-2	3-3	1-1			4
50/60	15	7.2	19	9.1	1-1	3-3	4-4	50/60	15	8.4	5-5	3-3	4-4			4

600 VOLT, SINGLE PHASE																
"LINE" CONNECTION				"BOOST" CONNECTION				"STEP-UP" CONNECTION				Model Numbers				
Output Voltage: 600				600												
Output Voltage: 0-600				0-600												
Constant Current Load				Constant Impedance Load				Terminals & Rotation				Manually Operated				
Freq. (Hz)	Max. Amps	Max. KVA	Max. Amps	Max. KVA	Input CW	Output CW	Jumper CW	Freq. (Hz)	Max. Amps	Max. KVA	Input CW	Output CW	Jumper CW	Manually Operated	Motor Driven	Conn. Diag.
60	15	9	19	11.4	4-4	3-3	1-1									4
60	15	9	19	11.4	1-1	3-3	4-4									4

120 VOLT, THREE PHASE OPEN DELTA																
"LINE" CONNECTION				"BOOST" CONNECTION				"STEP-UP" CONNECTION				Model Numbers				
Output Voltage: 120				120				N/A								
Output Voltage: 0-120				0-140												
Constant Current Load				Constant Impedance Load				Terminals & Rotation				Manually Operated				
Freq. (Hz)	Max. Amps	Max. KVA	Max. Amps	Max. KVA	Input CW	Output CW	Jumper CW	Freq. (Hz)	Max. Amps	Max. KVA	Input CW	Output CW	Jumper CW	Manually Operated	Motor Driven	Conn. Diag.
50/60	30	6.2	35	7.3	4-1, 4-1	3-1, 3-1	1-1, 4-4	50/60	30	7.3	2-1, 2-1	3-1, 3-1	1-1, 4-4			3
50/60	30	6.2	35	7.3	1-4, 1-4	3-4, 3-4	4-4, 4-4	50/60	30	7.3	5-4, 5-4	3-4, 3-4	4-4, 4-4			3

240 VOLT, THREE PHASE OPEN DELTA																
"LINE" CONNECTION				"BOOST" CONNECTION				"STEP-UP" CONNECTION				Model Numbers				
Output Voltage: 240				240				120								
Output Voltage: 0-240				0-208				0-242								
Constant Current Load				Constant Impedance Load				Terminals & Rotation				Manually Operated				
Freq. (Hz)	Max. Amps	Max. KVA	Max. Amps	Max. KVA	Input CW	Output CW	Jumper CW	Freq. (Hz)	Max. Amps	Max. KVA	Input CW	Output CW	Jumper CW	Manually Operated	Motor Driven	Conn. Diag.
50/60	15	6.2	19	7.9	4-4	3-3	1-1	50/60	15	7.3	5-4, 5-4	3-4, 3-4	4-4, 4-4			4
50/60	15	6.2	19	7.9	1-4, 1-4	3-4, 3-4	4-4, 4-4	50/60	15	7.3	6-4, 6-4	3-4, 3-4	4-4, 4-4			4

240Y/138 VOLT, THREE PHASE WYE																
"LINE" CONNECTION				"BOOST" CONNECTION				"STEP-UP" CONNECTION				Model Numbers				
Output Voltage: 240				240				120								
Output Voltage: 0-240				0-208				0-242								
Constant Current Load				Constant Impedance Load				Terminals & Rotation				Manually Operated				
Freq. (Hz)	Max. Amps	Max. KVA	Max. Amps	Max. KVA	Input CW	Output CW	Jumper CW	Freq. (Hz)	Max. Amps	Max. KVA	Input CW	Output CW	Jumper CW	Manually Operated	Motor Driven	Conn. Diag.
50/60	30	12.5	35	14.5	4-4, 4-4	3-3, 3-3	1-1, 1-1	60	30	14.5	2-2, 2-2	3-3, 3-3	1-1, 1-1			5
50/60	30	12.5	35	14.5	1-1, 1-1	3-3, 3-3	4-4, 4-4	60	30	14.5	5-5, 5-5	3-3, 3-3	4-4, 4-4			5

480Y/277 VOLT, THREE PHASE WYE																
"LINE" CONNECTION				"BOOST" CONNECTION				"STEP-UP" CONNECTION				Model Numbers				
Output Voltage: 480				380				240								
Output Voltage: 0-480				0-443				0-280								
Constant Current Load				Constant Impedance Load				Terminals & Rotation				Manually Operated				
Freq. (Hz)	Max. Amps	Max. KVA	Max. Amps	Max. KVA	Input CW	Output CW	Jumper CW	Freq. (Hz)	Max. Amps	Max. KVA	Input CW	Output CW	Jumper CW	Manually Operated	Motor Driven	Conn. Diag.
50/60	15	12.5	19	15.8	4-4, 4-4	3-3, 3-3	1-1, 1-1	60	15	14.5	2-2, 2-2	3-3, 3-3	1-1, 1-1			6
50/60	15	12.5	19	15.8	1-1, 1-1	3-3, 3-3	4-4, 4-4	60	15	14.5	5-5, 5-5	3-3, 3-3	4-4, 4-4			6

600Y/346 VOLT, THREE PHASE WYE																
"LINE" CONNECTION				"BOOST" CONNECTION				"STEP-UP" CONNECTION				Model Numbers				
Output Voltage: 600				600												
Output Voltage: 0-600				0-600												
Constant Current Load				Constant Impedance Load				Terminals & Rotation				Manually Operated				
Freq. (Hz)	Max. Amps	Max. KVA	Max. Amps	Max. KVA	Input CW	Output CW	Jumper CW	Freq. (Hz)	Max. Amps	Max. KVA	Input CW	Output CW	Jumper CW	Manually Operated	Motor Driven	Conn. Diag.
60	15	15.6	19	19.7	4-4, 4-4	3-3, 3-3	1-1, 1-1									6
60	15	15.6	19	19.7	1-1, 1-1	3-3, 3-3	4-4, 4-4									6

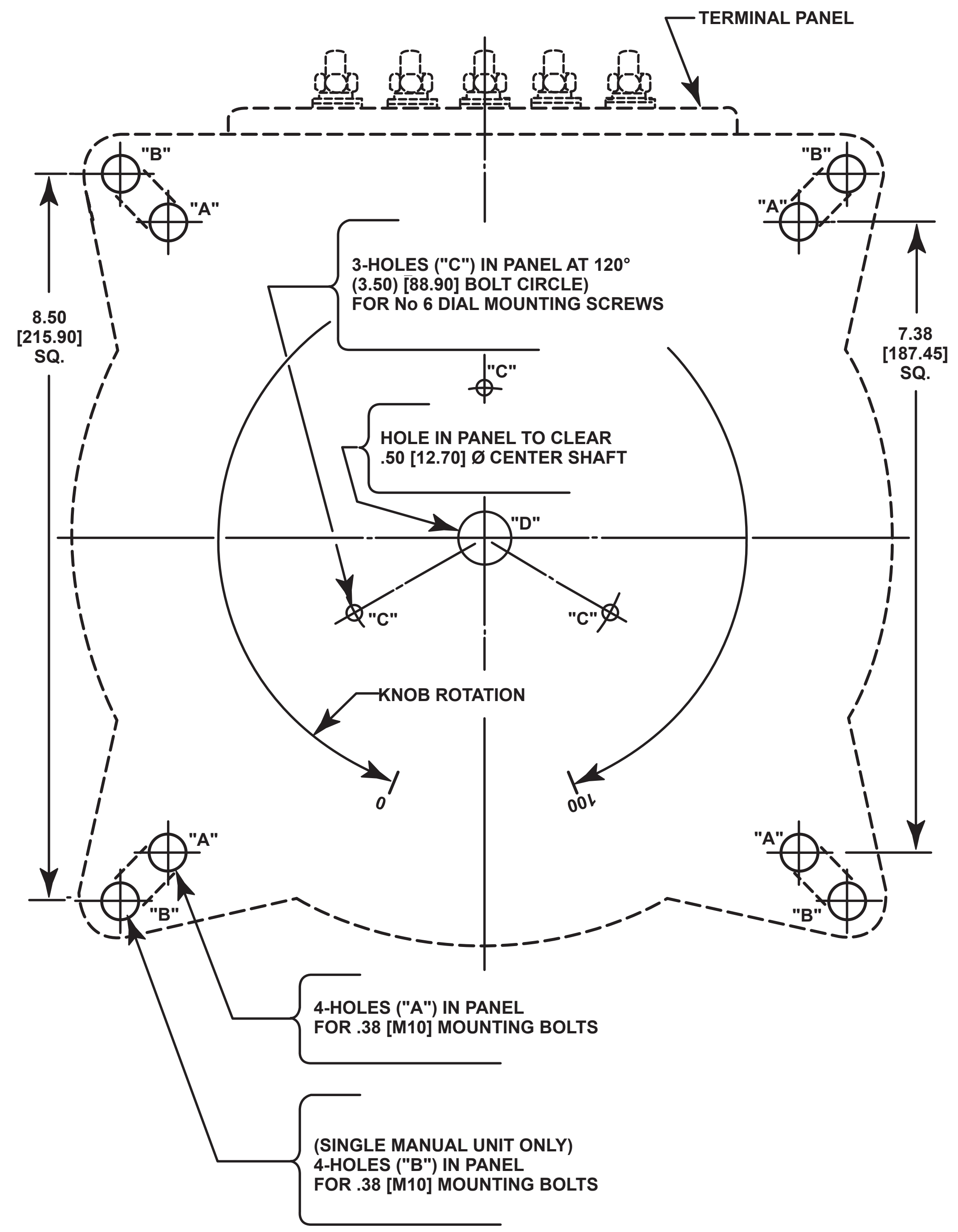
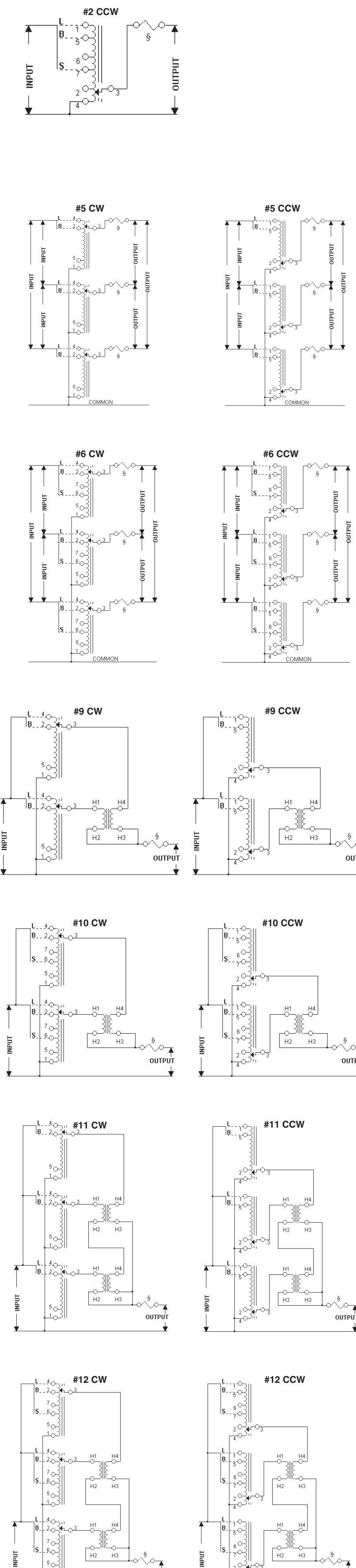

TEMPLATE N° 1

Please read important connection notes on other side.